

KNC-PLC-K541-CANopen Communication Module



FEATURES

- **Supports CAN2.0A and CAN2.0B Standard**
- **Communication Baudrates Ranging from 10K~1Mbps**
- **Boot-Up Configurable via KincoBuilder**
- **Supports:**
 - **72 CANopen Slave Stations**
 - **Network Management (NMT)**
 - **Process Data Objects (PDO)**
 - **Service Data Objects (SDO)**
 - **Preset Emergency Messages**
 - **Node Protection**
 - **Heartbeat Messages**



DESCRIPTION

Kinco offers a CAN module to attach to the K5 CPU series for communication with various CAN devices. CAN is a robust communication protocol that allows for an elaborate serial network to deploy in any industrial or commercial atmosphere. The PLC-K541 supports both the CAN2.0 and CAN2.0B communication standard. CAN offers message hierarchy schemes and enables you to connect with up to 72 devices on a single network. CAN is a peer-to-peer network, meaning there is no master that decides when to read or write data to the CAN bus. When a CAN node is ready to write to the CAN bus it simply checks to see if the bus is busy and writes to the network. CAN frames do not contain addresses instead an arbitration ID that is unique through the network labels the frame. Each node receives the frame and depending on the arbitration ID of the frame, each CAN node on the network decides whether to accept the frame.

SPECIFICATIONS

Parameter	KNC-PLC-K541
Function	CANopen Master Station and CAN Free Protocol Communication
Communication Baudrate	Support 10 K - 1 Mbps
Electrical Isolation	Power Supply, Communication Circuit are Separated from External, Isolation Voltage is 2500 Vac /1 min Max.
Signal Indication	Separated LED indicates Power, Working Status, and Communication Status
Support PDO	Slave Stations Support up to 8 TPDO's and 8 RPTO's, Up to 256 Total for Each.
Module Width	50 mm

L011165



In each system, the CPU module is arranged in the leftmost end, and expansion modules are connected to the expansion interface on the right.

A cable slot is designed on the left side of each expansion module. The expansion cable can be put in the cable slot to ensure seamless interconnection between modules after installing.

KNC-PLC-K541

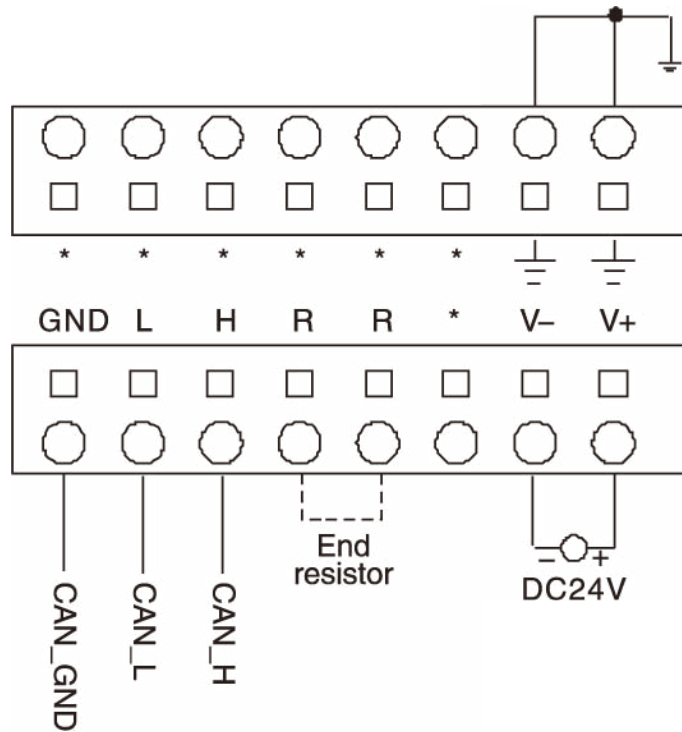

L011165